

GUIDELINES FOR STANDARD SAMPLING PIPE NETWORKS

Introduction

This section provides examples of the most widely used formats for sampling pipe networks. The recommendations the designer should use in determining the position and spacing between sampling pipes and holes are given in the section 'Air Sampling Network Design'

It must be remembered that the performance of an aspirating smoke detection system is partially dependent on the effectiveness of the sampling pipe network. It may be necessary to model the network on PipeCAD[®] to verify the proposal will operate within the design parameters and that the design complies with local codes, standards or regulations.

The basic sampling system

The basic sampling system can be described as a network of pipes suspended over or positioned within the area/volume to be protected. A variety of arrangements are possible, each with up to four pipes that are connected to the inlet ports of the Stratos-HSSD[®] detector. The arrangement of the sampling system should be such that a distribution of small holes is drilled in the sampling pipes. For simplicity and compliance with local codes it may be appropriate to position each of these sampling points in the position that would normally be occupied by a conventional point type detector. The floor area below each sampling hole ('detector') should be approximately equal.

The aspirator within the Stratos detector draws a continuous sample of air through these holes, and passes it through a laser based detector within the same cabinet. It is normal to fit a vented end-cap on each run of pipe although it is not essential for this hole to be in an end cap. It is the sampling hole most distant from the aspirator and detector and may be a simple drilling in the sampling pipe or an extended sampling point. The size of the drilled vent would normally be between 4 - 8 mm. The purpose of this vent is to balance the volume of air flowing through the holes near the end of the sampling pipe, where pressures will be relatively low. The volume of air flowing through each hole or sampling point determines its level of sensitivity. This technique is the basis of all other air sampling pipe arrangements.

Sampling below ceilings

Standard Sampling pipe systems

Applications for below ceiling sampling pipe systems include: offices, heritage buildings, auditorium areas, aircraft hangars, stores, warehouses, atria, manufacturing plants, hospitals, hotels, or any other areas without high air velocities or close-control air-conditioning. This method may also be appropriate for the protection of Electronic Data Processing areas (computer rooms) and telecommunications installations that do not have high air velocities. Where these applications do have high velocity airflow, the below-ceiling method should be considered as a Secondary system. The Primary system should be a method of sampling that is capable of detecting small traces of smoke in high airflow situations.

GUIDE LINES FOR SAMPLING NETWORK

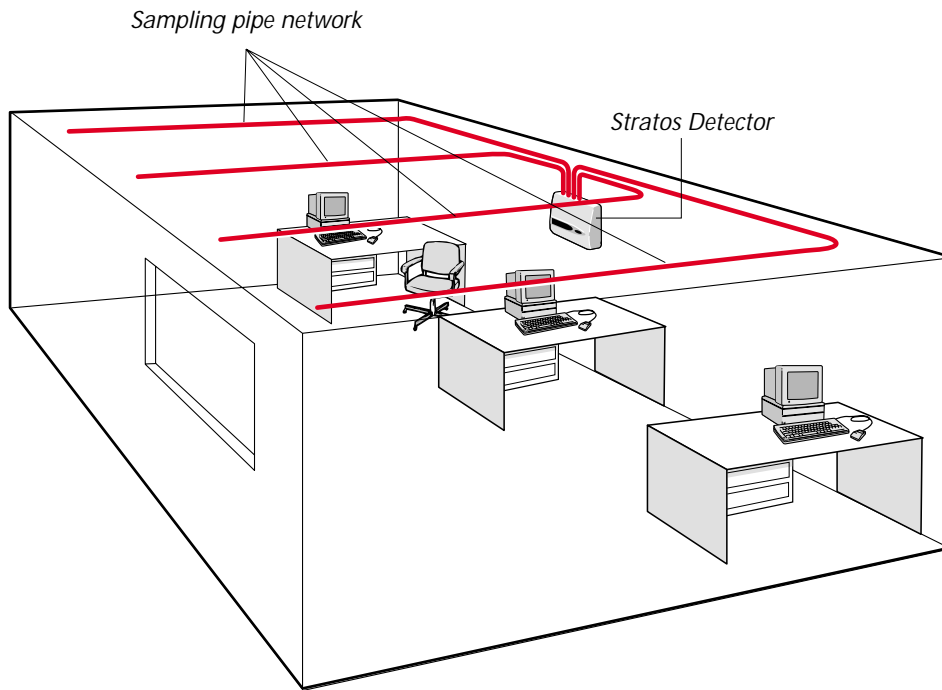

Fig. 1 A typical below ceiling sampling network

Figure 1. shows a typical layout of a below ceiling sampling pipe system designed on the grid layout method.

For below-ceiling applications the sampling pipe should be fixed so that the sampling points are 25 - 600 mm below the level of the ceiling and facing down into the room space. This locates the sampling points beneath any small boundary layer of air between the ceiling and smoke that has been observed in actual fire and pre-fire conditions. The minimum and maximum distances below the ceiling may vary between local codes, standards or regulations. Figure 2. illustrates the arrangement.

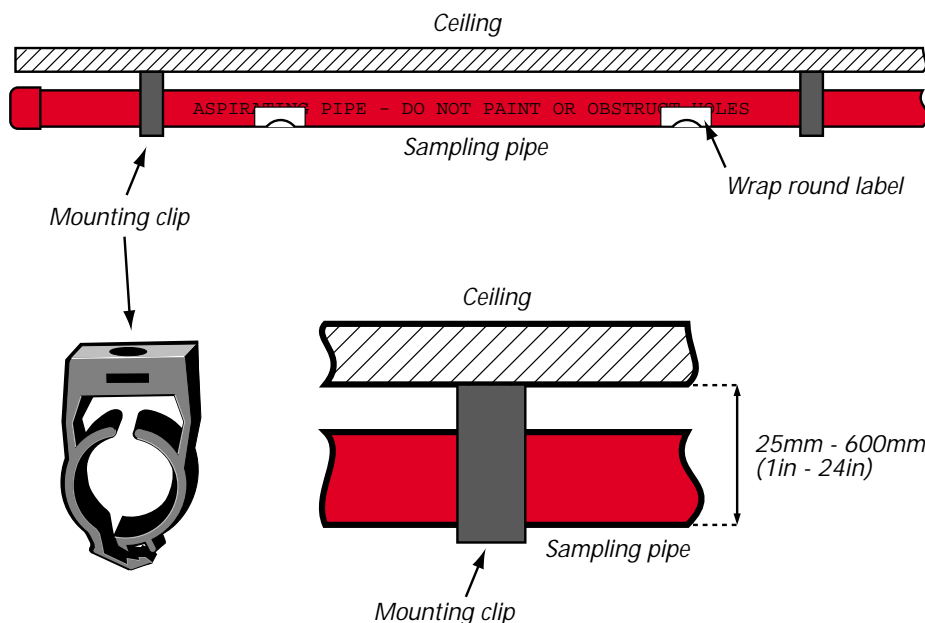

Fig. 2 Details of pipe fixing below ceilings

GUIDE LINES FOR SAMPLING NETWORK

If the ceiling is pitched, sloping or north-light type, the sampling pipe can be installed to run either across or along the ceiling. A wide range of fixing systems is commercially available to enable the installer to mount the sampling pipe on the support structures. Figures 3. And 4. illustrate this.

Fig. 3 Sampling pipe following line of pitched North-light roof

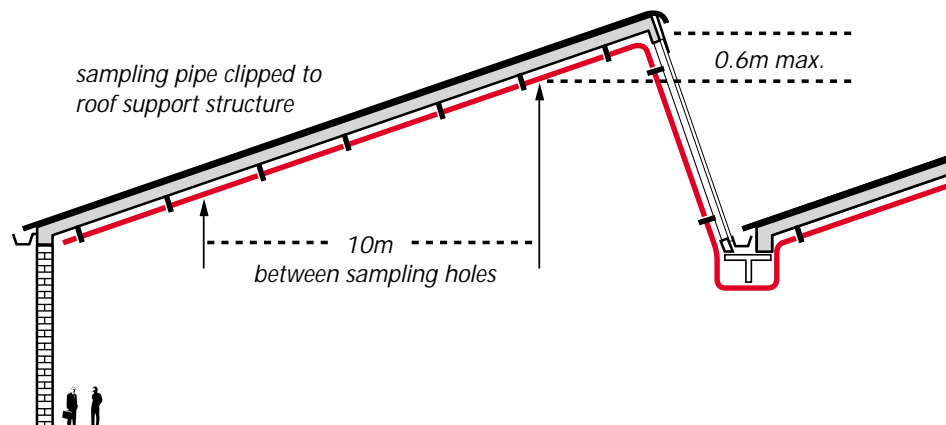
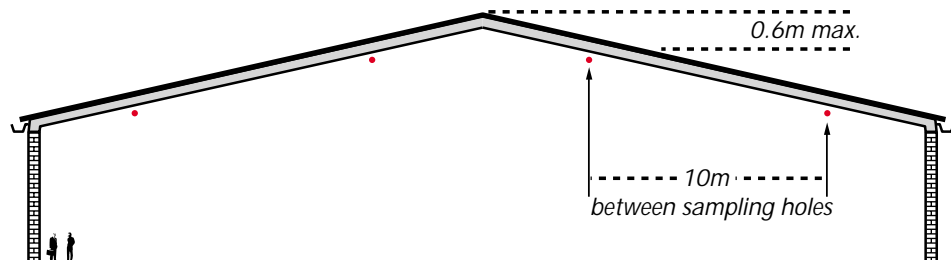

Fig. 4 Sampling pipe traversing low pitched roof



Remote test points

In larger buildings the sampling pipe network and sampling holes could be a considerable distance from floor level. This may make routine response testing difficult or impossible without the aid of access equipment. Under these circumstances it may be worthwhile extending the far end of each sampling pipe branch to an accessible position. For the purpose of routine testing a drilled end cap assembly can be substituted for the blank unit and a smoke test undertaken.

The actual response time would be longer than normally expected but providing the response time is consistent at each point for every test undertaken, this is of no great concern. Figure 5. illustrates a typical example of a remote test point

GUIDE LINES FOR SAMPLING NETWORK

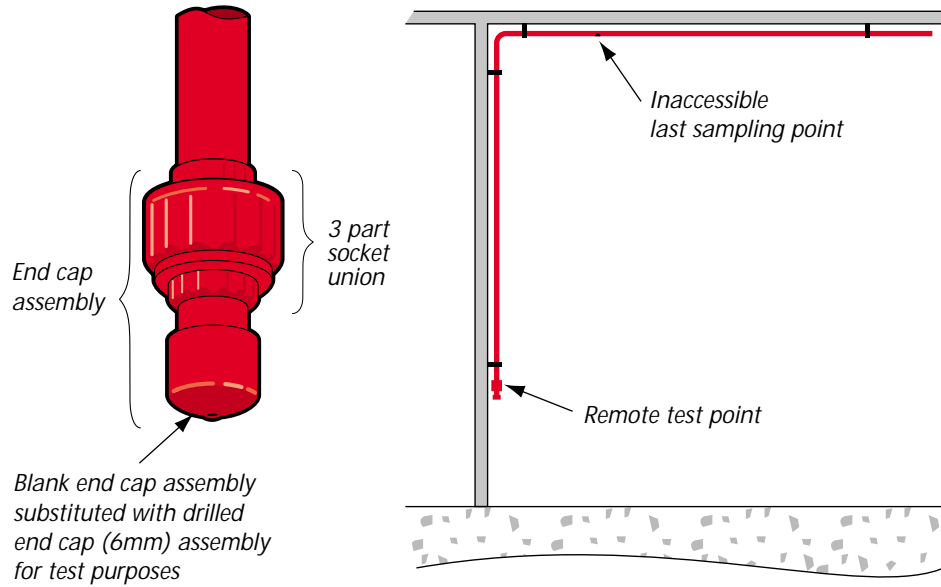

Fig. 5 Illustration of a remote test point

There is sometimes a requirement to provide smoke detection in ceiling or floor spaces. Aspirating smoke detection systems are particularly effective in this application as the need to gain access for routine maintenance is reduced or non-existent. (See figure 6)

Sampling above ceilings and below floors

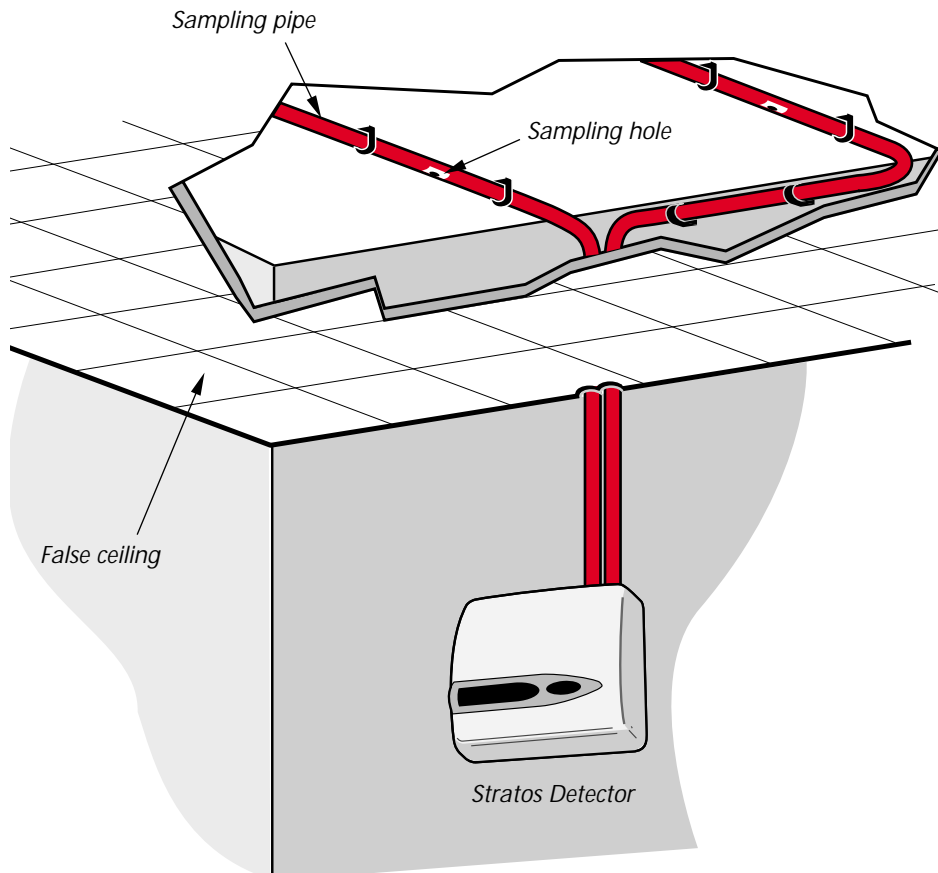

Fig. 6 Sampling pipe installed above a suspended ceiling

GUIDE LINES FOR SAMPLING NETWORK

■ Sampling pipes running in ceiling spaces should be fixed to the roof slab, joists or support beams using suitable fixings. Alternatively, it may be possible to secure the sampling pipe to the suspended ceiling supports using plastic or metallic ties, providing a secure fixing can be made. (See figures 7. 8. 9.)

Fig. 7 Sampling pipe fixed to ceiling slab.

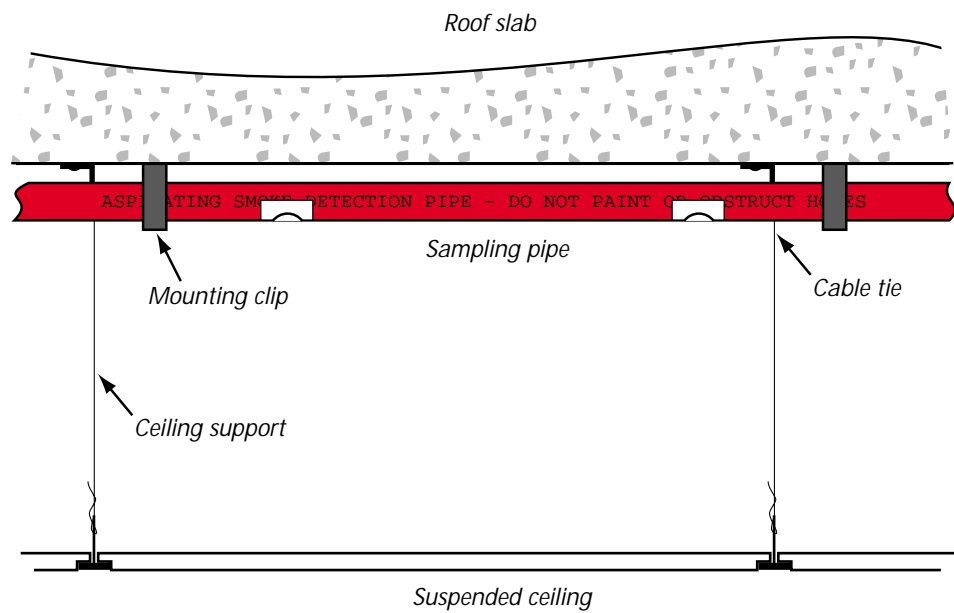
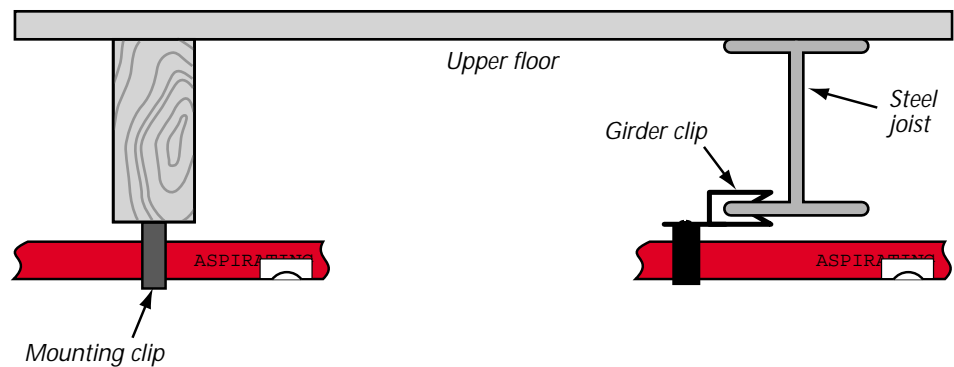

Fig.8 Examples of pipe fixings.



GUIDE LINES FOR SAMPLING NETWORK

■ In rooms where the ceiling space is used as the ventilation return air path, a sampling pipe network can be installed to monitor the air as it leaves the room space. (See figure 11.)

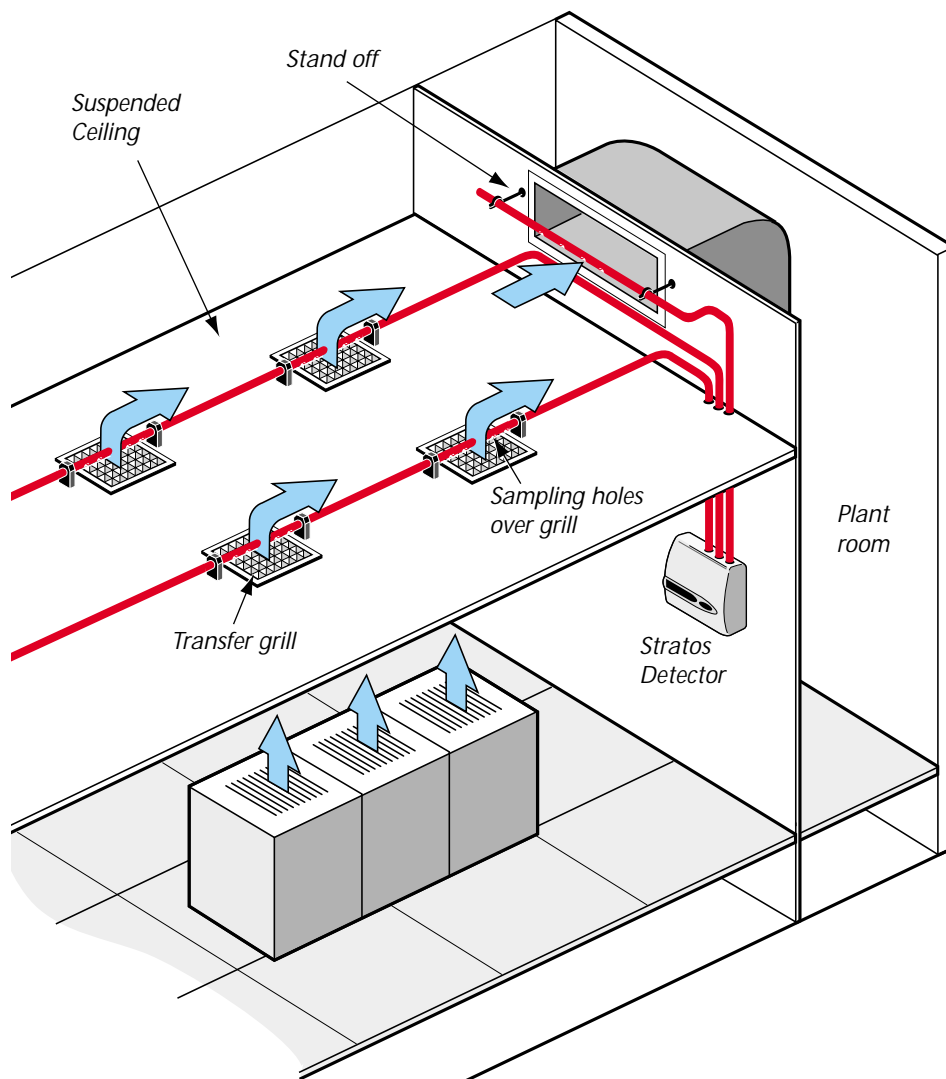
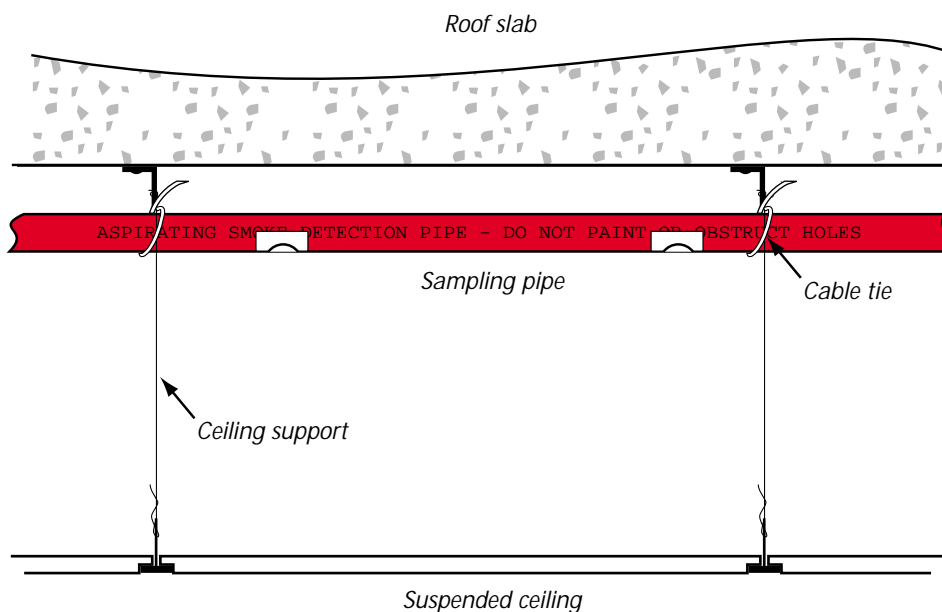

Fig. 11 Sampling air at it leaves the room space. This is an example of 'primary' detection

GUIDE LINES FOR SAMPLING NETWORK

Fig. 9 Attaching sampling pipe to suspended ceiling supports



■ Some ceiling spaces may have deep transverse beams that divide the space into compartments. Under some circumstances it may be necessary to run the sampling pipe below the false ceiling to enable full coverage to be given. (See figure 10.) For some applications it may be preferable to use extended sampling point techniques.

Fig. 10 Example of sampling pipe routing.

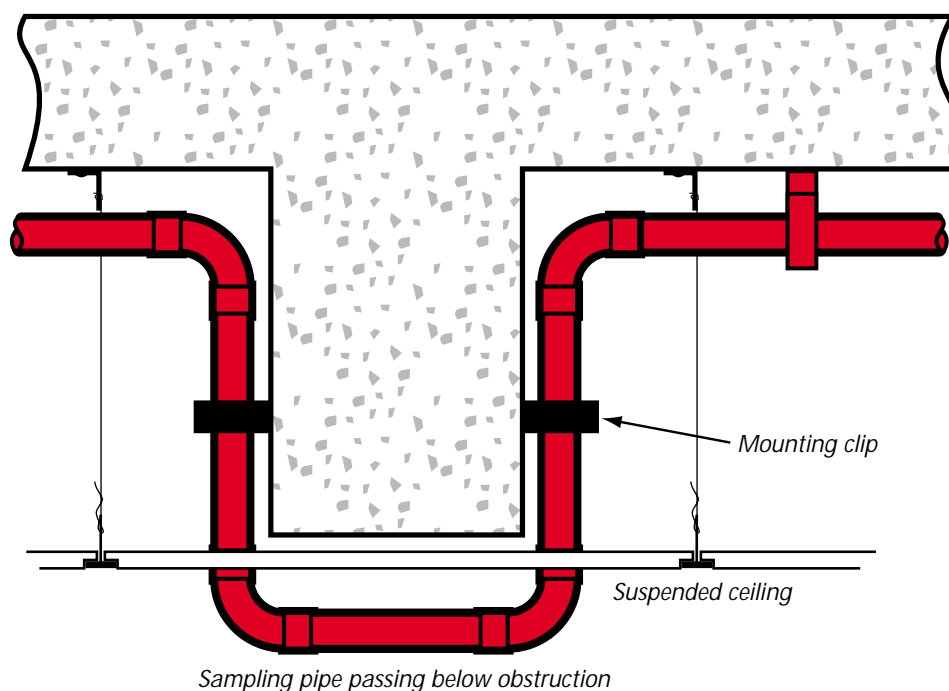

GUIDE LINES FOR SAMPLING NETWORK

■ A standard sampling system based on a grid pattern can be used to monitor the interconnecting and power cabling normally found in computer room floor voids. (See figure 12.)

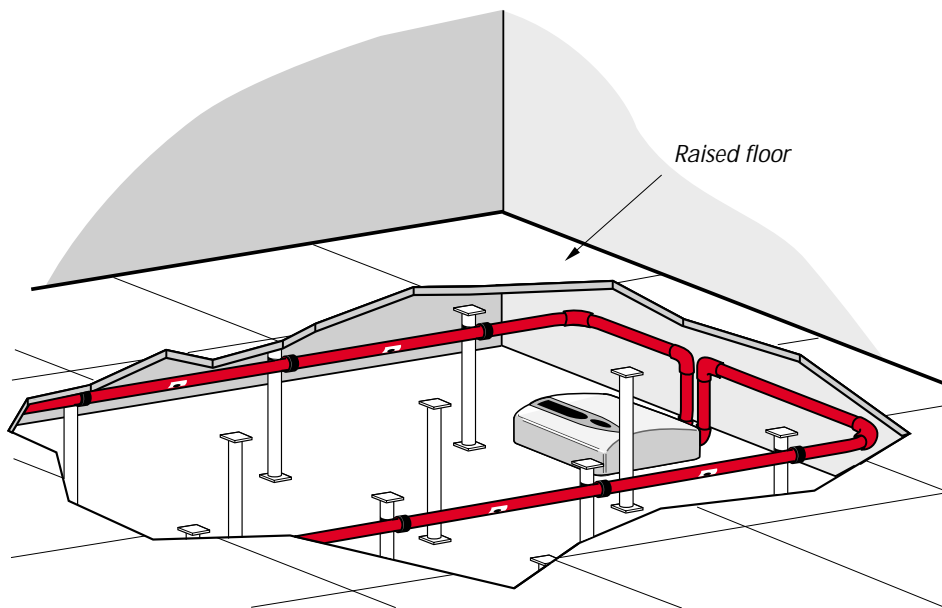

Fig. 12 Sampling from below a raised access floor

■ The sampling pipe network should be installed toward the top of the floor space using either supports from the floor or fastenings to the raised floor supports using fixing clips or ties. The type of fixing clip used depends on the construction of the raised floor support and may need to be built specially for the project. (See figure 13.)

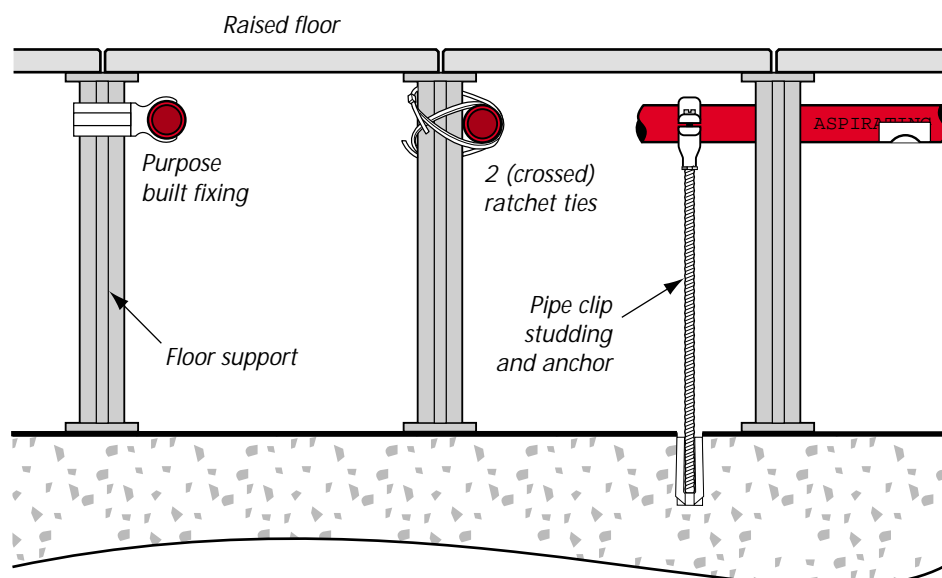
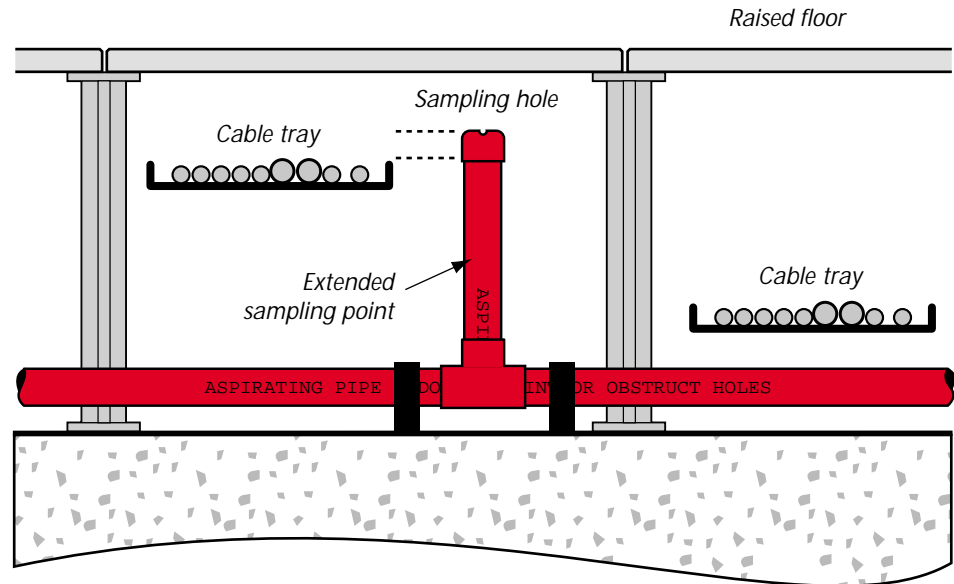

Fig. 13 Alternative methods of fixing sampling pipe below a raised floor.

GUIDE LINES FOR SAMPLING NETWORK

■ Where structured cabling systems are installed in floor voids, a rigid extended sampling system may prove suitable. (See figure 14.) Care should be taken not to trap any existing cabling or services below the sampling pipework.

Fig. 14 Example of an extended sampling point



Siting Stratos-HSSD® detector outside the protected area

It may be a requirement of the project that the detector is sited outside the space being protected. Consideration should be given to the possibility that there are, or could be, differences in the air pressure between these positions. To ensure fluctuations in air pressure do not generate unwanted airflow fault signals, the exhaust of the Stratos-HSSD® should be piped back into the area being protected. Figure 15a and b. describes the principle.

Fig. 15a Piping the exhaust of the Stratos detector back into the protected space.

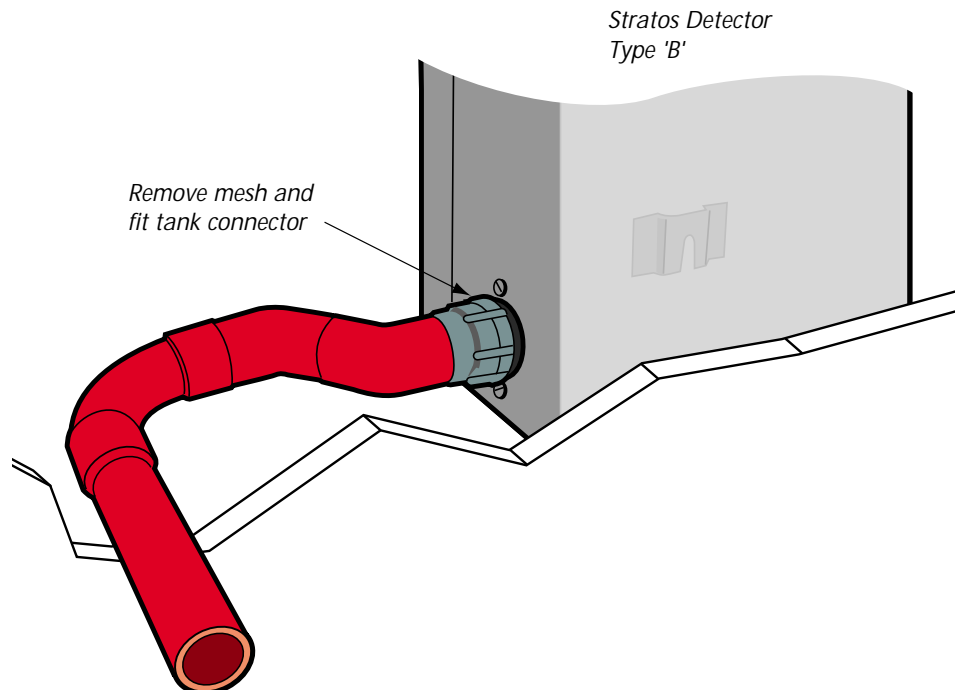

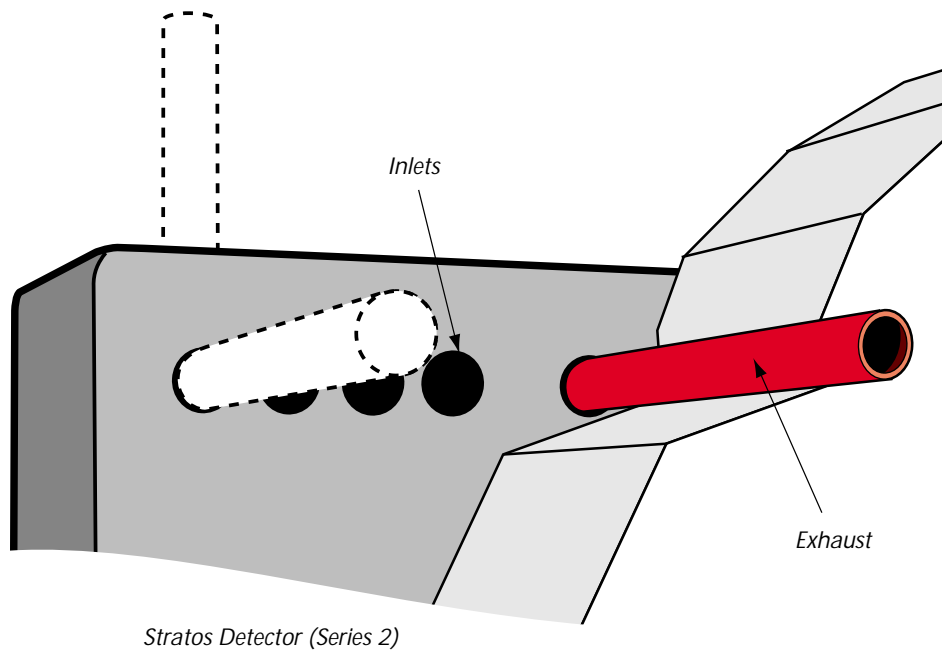

Fig. 15b

A common application for Stratos-HSSD® or Stratos-Quadra® is to provide a high level of smoke detection for equipment cabinets. For sealed cabinets housing process control electrical, electronic equipment or switchgear it is often possible to install the sampling pipe network within the cabinet(s). The same principle can be used within cable trays and trunking.

- One benefit of this method is that (assuming the sampling pipe material is non-metallic such as ABS) the network itself is inert. The sampling pipework will not pose a threat to power switching or sensitive electronics, neither is it likely that electromagnetic interference within the enclosure(s) will cause unwanted alarms.
- An in-cabinet smoke detection system should not be expected to offer protection to the environment outside the enclosures. If this is required additional Stratos-HSSD® or conventional detection should be provided.
- As the total volume protected is relatively small, general system sensitivity will be high and the Stratos-HSSD® will respond rapidly to very small densities of smoke generated within the cabinets. Even so, due consideration should be given to limiting the total number of enclosures protected by each Stratos detector to a number that may be readily inspected by available staff.
- As the total volume protected is relatively small, general system sensitivity will be high and the Stratos-HSSD® will respond rapidly to very small densities of smoke generated within the cabinets. Even so, due consideration should be given to limiting the total number of enclosures protected by each Stratos detector to a number that may be readily inspected by available staff.

Further information on sampling from within cabinets is given in the section titled 'Capillary Sampling'

Sampling from
equipment
cabinets

**Sampling pipe
within cabinets**

GUIDE LINES FOR SAMPLING NETWORK

Fig. 16 Typical sampling pipe layout within three cabinets

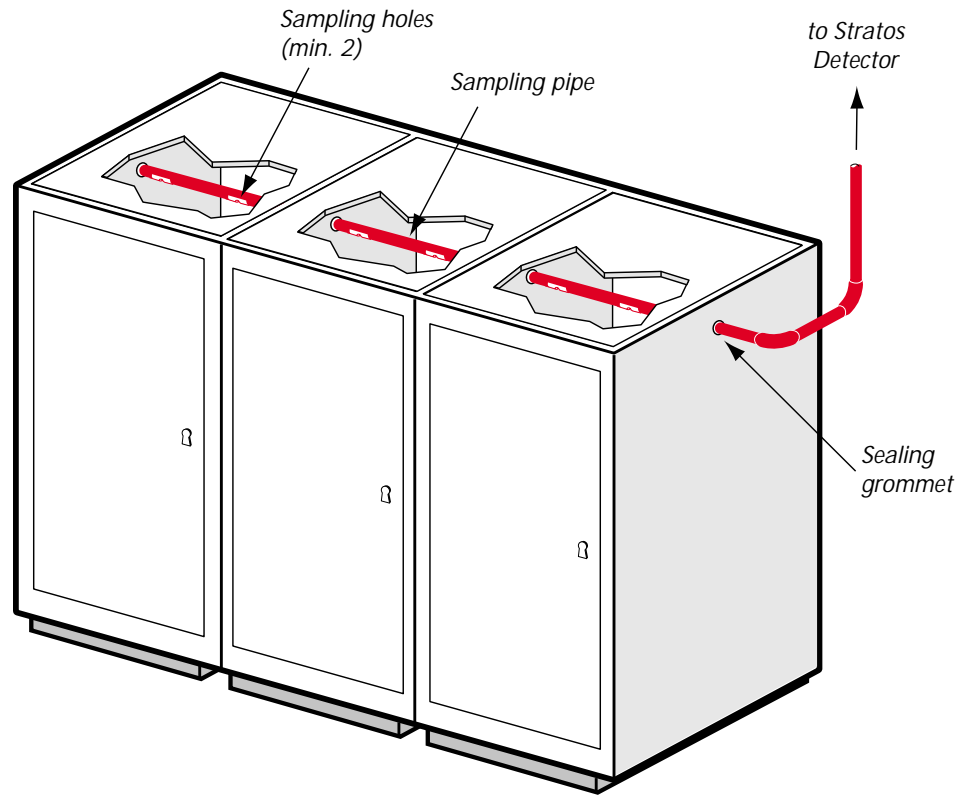
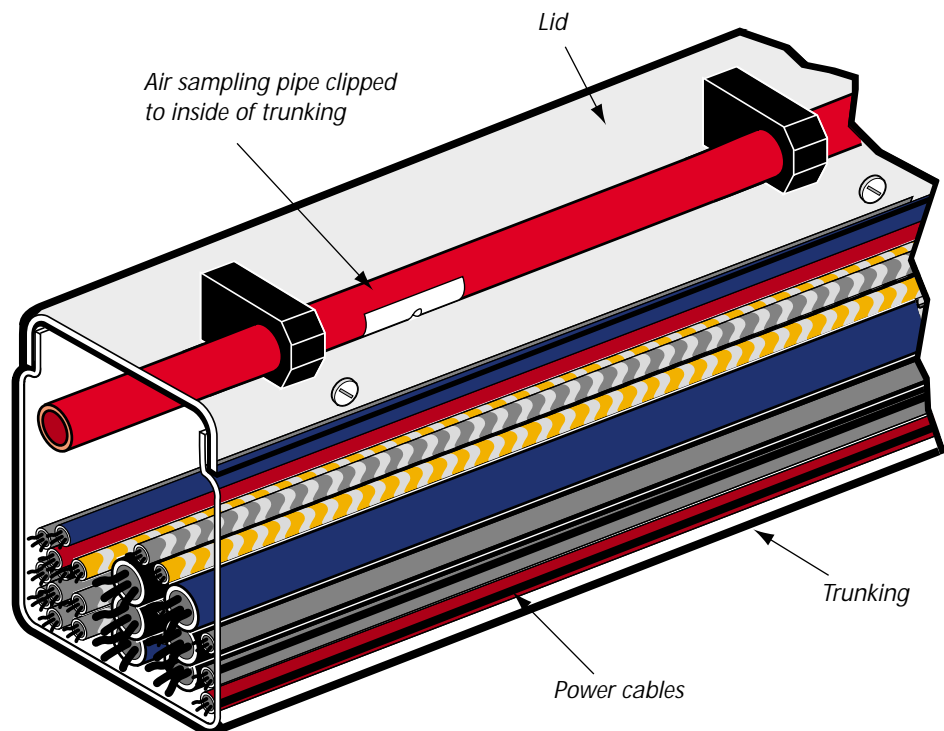

Fig. 17 Sampling pipe network installed inside cable duct



Above-cabinet sampling techniques can be used where monitoring is required above electrical equipment cabinets, equipment racks, consoles, cable trays or similar.

Sampling above equipment cabinets

Sampling pipes are placed directly above the cabinet, console, etc. in the path of any available air currents generated by ventilation sources or thermal energy. (see figures 18 and 19.)

- The sampling pipe should be fitted in the centre of the exhaust air stream(s) or directly above the object to be protected.
- Sampling holes should face into the air stream or the object to be protected.
- If there are a number of exhausts from an enclosure, sampling points should be installed over each opening.
- If the exhaust outlet is large, it is necessary to ensure the position or numbers of the sampling pipes and its sampling holes are adequate to be effective for all potential incidents. If possible, a series of smoke tests should be performed to verify the efficiency of the installation. (See figure 19.)

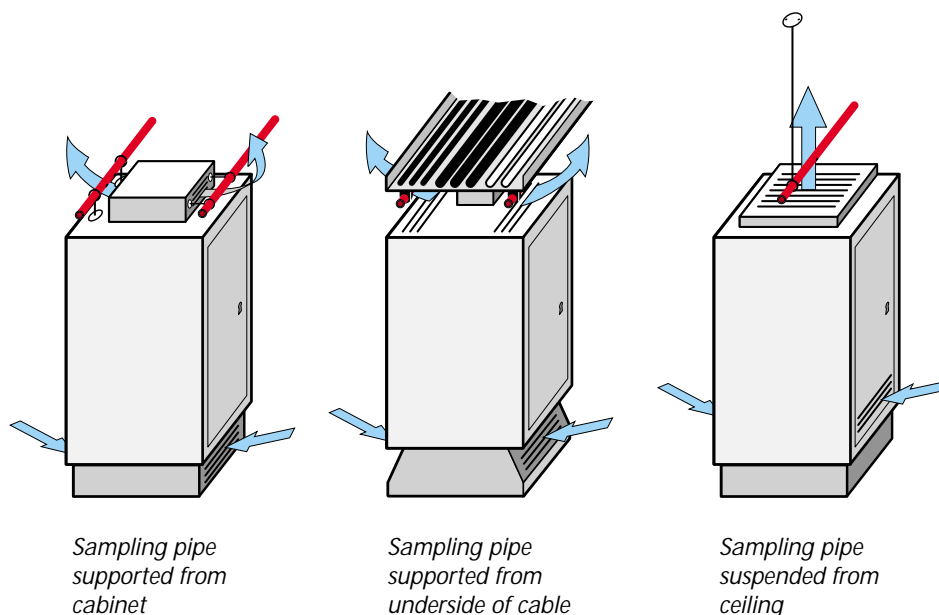
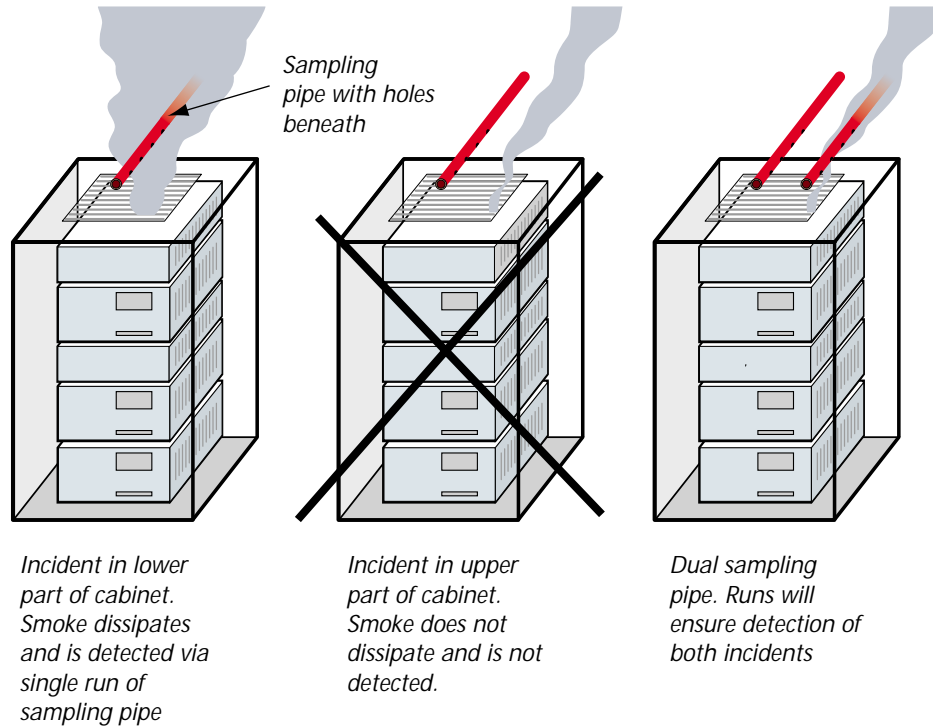

Fig. 18 *Sampling above equipment cabinets showing some of the possible configurations*

GUIDE LINES FOR SAMPLING NETWORK

Fig. 19 *Sampling above cabinets showing importance of thorough testing*



GUIDE LINES FOR SAMPLING NETWORK

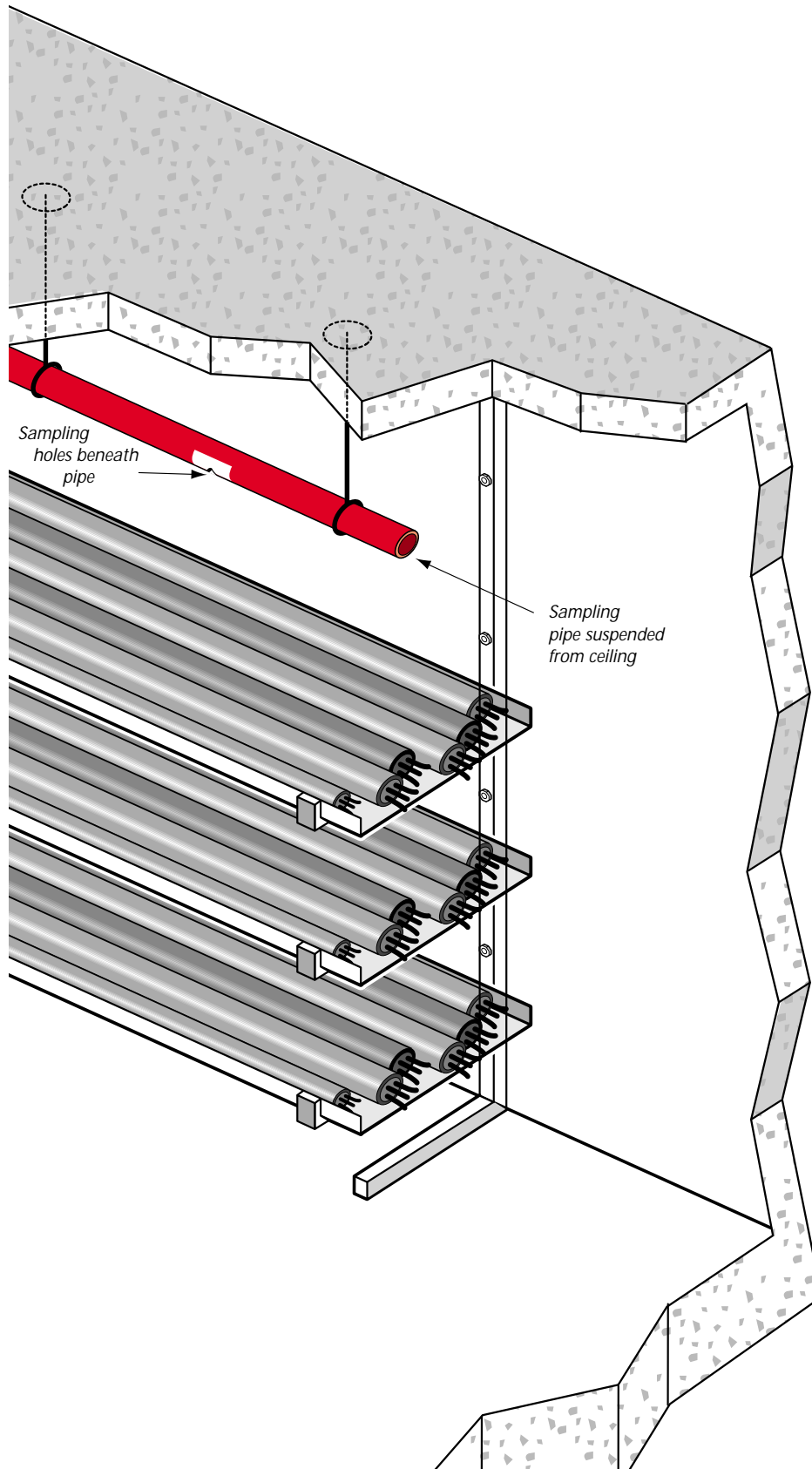

Fig. 20 Sampling pipe network covering electrical power distribution cables.